

The **NORCHEM AnCAT Model 058D-14** automatic liquid polymer system is designed to process up to .58 GPH of a neat liquid polymer and deliver 1.0 to 8.0 GPM (60 to 480 GPH) of a nominal 0.1 to 2.0% aqueous polymer solution. The 058D-14 system is modular in design consisting of a liquid polymer injection module and booster module assembly.

**AnCAT MODEL 058D-14 LIQUID POLYMER SYSTEM SPECIFICATIONS**

<b>FRAME:</b>	<b>BASE:</b>	<b>18" W x 18" L x 24" H</b>
	<b>CONSTRUCTION:</b>	<b>304SS BASE</b>
<b>INJECTION MODULE:</b>	<b>PUMP:</b>	<b>DIAPHRAGM-TYPE, HIGH VISCOSITY</b>
	<b>DRIVE:</b>	<b>ENCAPSULATED SOLENOID PULSE DRIVE</b>
	<b>CAPACITY:</b>	<b>NEAT POLYMER FLOWRATE 0.0 – .58 GPH (14 GPD)</b>
<b>BOOSTER MODULE:</b>	<b>PUMP:</b>	<b>CENTRIFUGAL-TYPE, CAST IRON, MODIFIED FOR POLYMERS</b>
	<b>DRIVE:</b>	<b>CLOSE-COUPLED</b>
	<b>MOTOR:</b>	<b>.75 HP, 3450 RPM, CONTINUOUS DUTY, ODP</b>
	<b>DISCHARGE:</b>	<b>10 – 60 PSI 1.0 – 8.0 GPM</b>
<b>SOLUTION OUTPUT:</b>	<b>PRIMARY FLOW:</b>	<b>3.0 – 8.0 GPM (480 GPH)</b>
	<b>SECONDARY FLOW:</b>	<b>NONE</b>
	<b>TOTAL FLOW:</b>	<b>3.0 – 8.0 GPM (480 GPH)</b>
<b>CONCENTRATION:</b>	<b>SOLUTION:</b>	<b>PRIMARY 0.2 – 2.0% VOLUME ON VOLUME</b>
		<b>TOTAL 0.2 – 2.0% VOLUME ON VOLUME</b>
<b>UTILITIES:</b>	<b>ELECTRICAL:</b>	<b>120/1/60 20 AMPS</b>
	<b>WATER:</b>	<b>40 – 100 PSI 25 GPM CLEAN SOURCE</b>
<b>CONTROLS:</b>	<b>CONTROLLER:</b>	<b>(OPTIONAL) NEMA 4X W/ TOUCHPAD, POLYMER RATIO, REMOTE START/STOP, POLYMER PUMP READOUT, WATER RATIO, PRIMARY AND SECONDARY FLOW READOUTS, REMOTE SETPOINT AND DOSING CONTROL, AUTO CALIBRATION AND ALARMS</b>
	<b>LOW WATER:</b>	<b>(OPTIONAL) FLOW SENSOR WITH AUTO RESTART OR MANUAL RESET</b>
	<b>LOW POLYMER:</b>	<b>(OPTIONAL) OPTICAL SENSORS WITH ADJUSTABLE RANGE 0.15 – 2.0% CONCENTRATION</b>

**ENGINEERING SPECIFICATIONS:**

**AnCAT Model 058D-14** shall be provided to rapidly dilute, activate and feed emulsion, dispersion and solution polymers at 480 GPH of polymer solution at concentrations to 2%. The system shall contain a four step controlled energy hydraulic circuit which instantaneously dilutes and blends the polymer to it's most efficient state for use in the process. The unit shall be designed with full pressure-controlled, inline inversion capability and shall not be limited by a minimum retention time restriction. The polymer system shall be capable of providing a 15 – 20 PSI pressure boost and shall not rely on available inlet water pressure to discharge the polymer solution product. The system shall be modular in design and shall consist of a polymer injection module, booster module, premix manifold assembly, inlet water solenoid valve, primary and secondary inlet water flowmeter, primary and secondary inlet water flow controllers, proportioning pressure regulator to balance primary and secondary flow circuits, mixing pressure regulator adjustable from 10 to 70 PSI, mixing circuit pressure gauge and inlet water throttling valve.

# PLAN & ELEVATION

# AnCAT 05D-SERIES

05D\_DIM

(TYPICAL FOR ALL 054D AND 058D SYSTEMS)

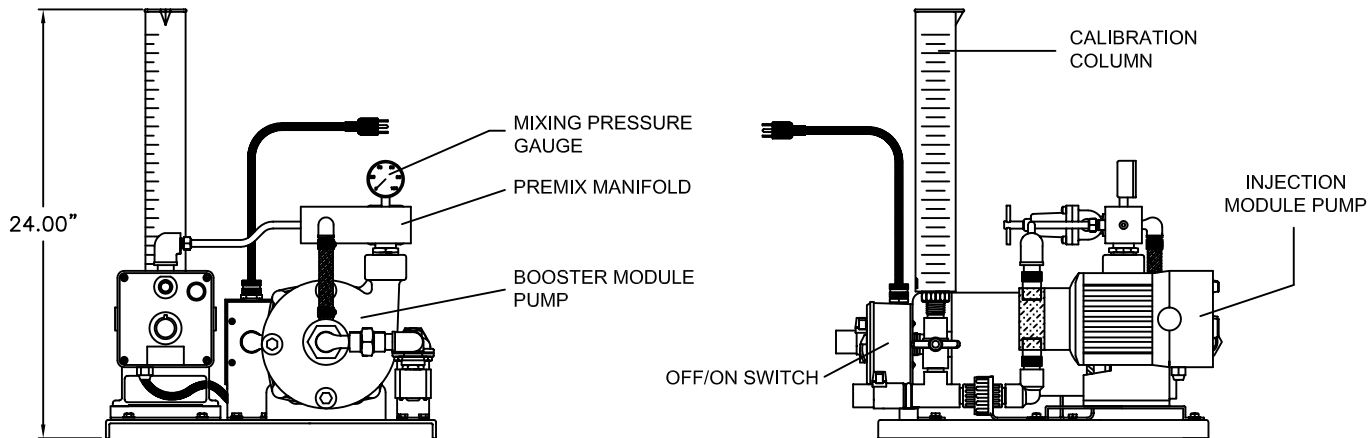

FRONT VIEW

LEFT END VIEW

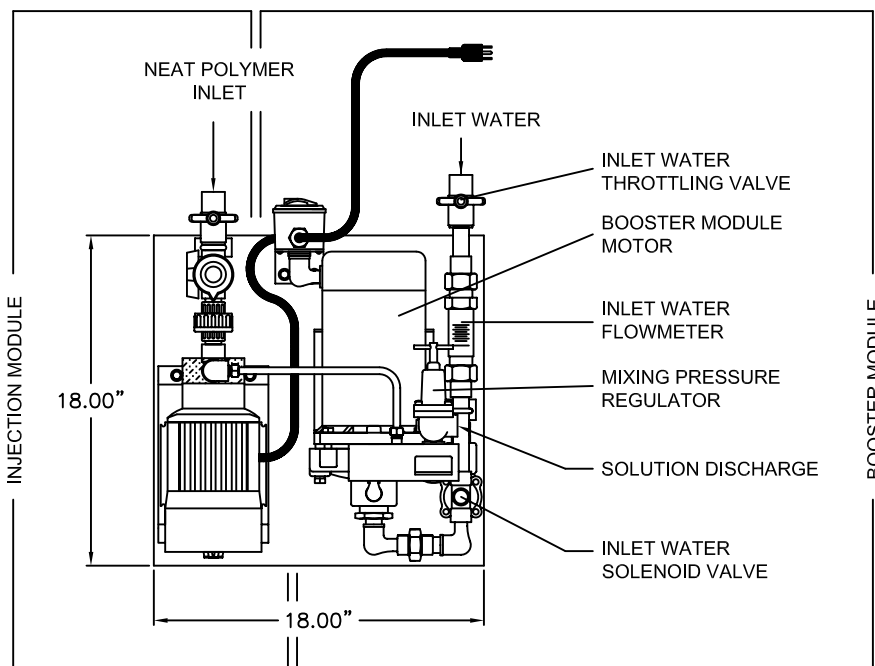

PLAN VIEW

# NORCHEM INC.

# ELECTRICAL SCHEMATIC

# AnCAT 05D-SERIES

05D\_ELE

(TYPICAL TO ALL 054D AND 058D SERIES SYSTEMS)

INCOMING POWER  
115 VAC/1 PH/60 HZ

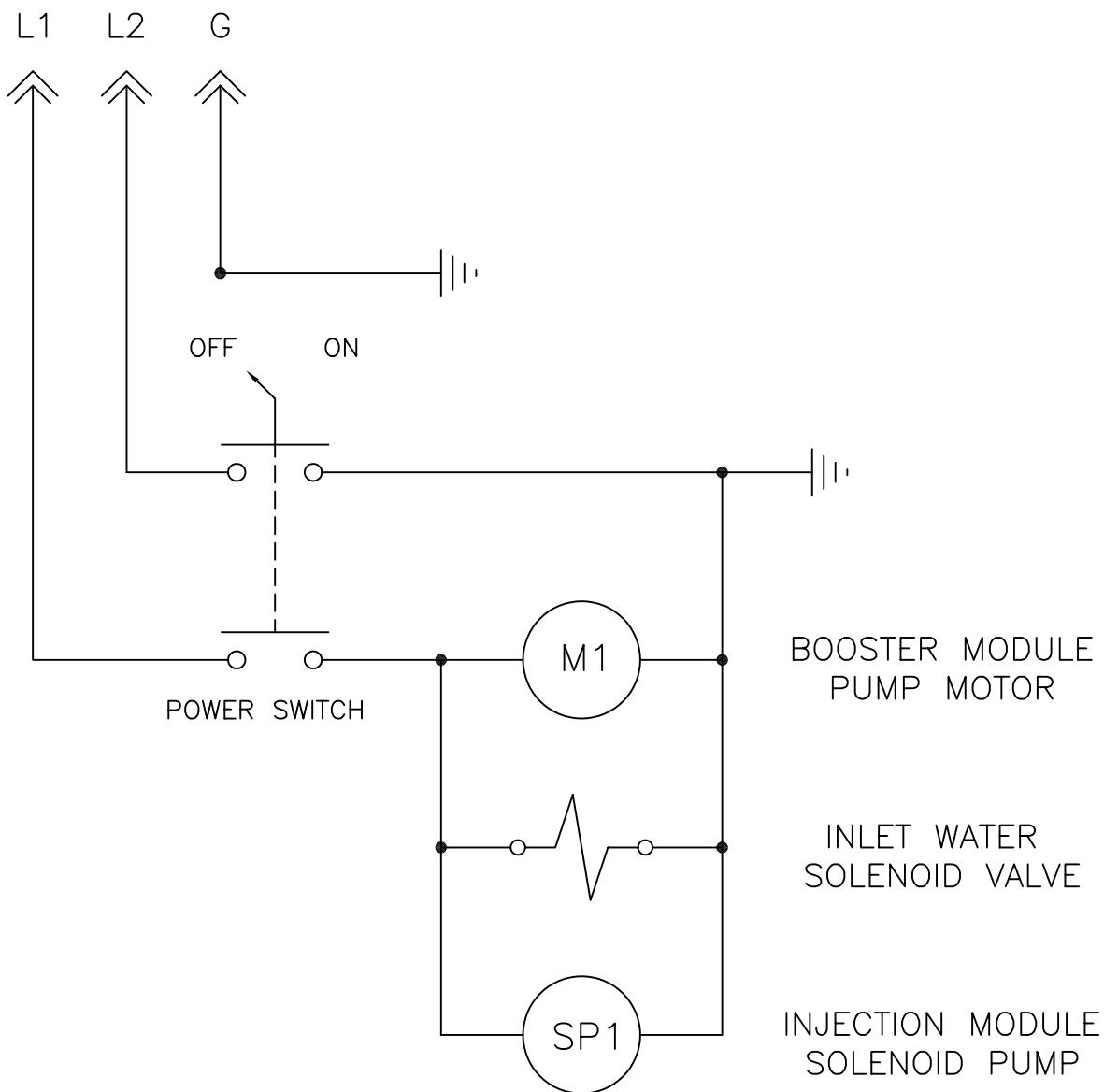

## NORCHEM INC.

(TYPICAL TO ALL 054D AND 058D SYSTEMS)

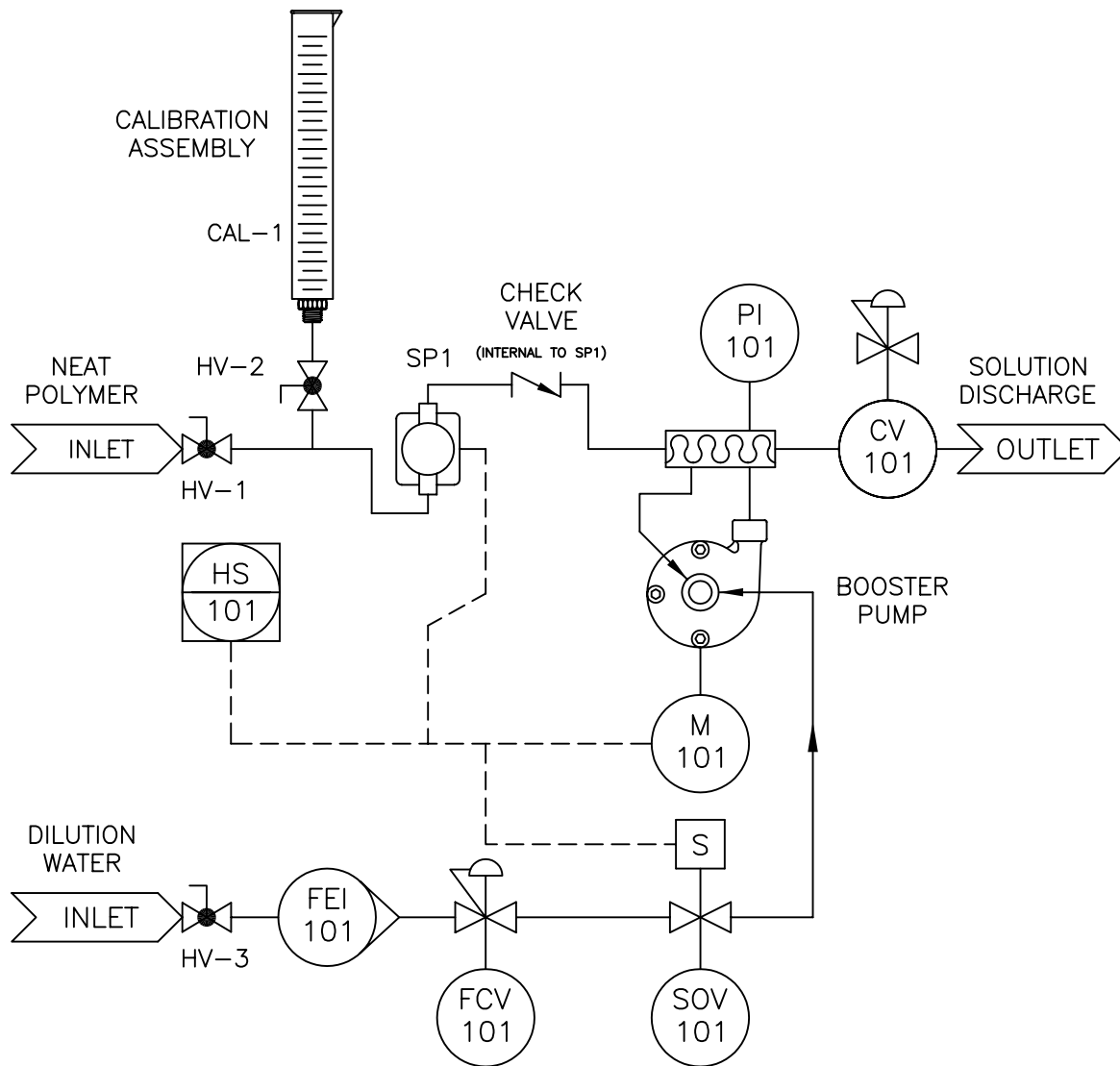

**LEGEND**

HV-1	POLYMER SUPPLY SHUTOFF HAND VALVE
HV-2	CALIBRATION ASSEMBLY ISOLATION HAND VALVE
HV-3	INLET WATER THROTTLING VALVE
CAL-1	CALIBRATION CYLINDER
PI-101	MIXING PRESSURE GAUGE
SP1	INJECTION MODULE SOLENOID PUMP w/INTERNAL CHECK VALVE
M-101	BOOSTER PUMP MOTOR
SOV-1	DILUTION WATER INLET SOLENOID VALVE
CV-101	MIXING PRESSURE CONTROL VALVE
FEI-101	DILUTION WATER INDICATING FLOW METER
FCV-101	DILUTION WATER FLOW CONTROL REGULATOR
HS-101	OFF/ON SWITCH