

The **NORCHEM AnCAT Model 058GS-100** automatic liquid polymer system is designed to process up to 4.2 GPH of a neat liquid polymer and deliver 1.0 to 8.0 GPM (60 to 480 GPH) of a nominal 0.1 to 2.0% aqueous polymer solution. The 058GS-100 system is modular in design consisting of a liquid polymer injection module and booster module assembly.

AnCAT MODEL 058GS-100 LIQUID POLYMER SYSTEM SPECIFICATIONS

FRAME:	BASE:	24" W x 24" L x 26" H
	CONSTRUCTION:	304SS BASE
INJECTION MODULE:	PUMP:	ROTARY-GEAR-TYPE, 316 STAINLESS STEEL
	DRIVE:	POSITIVE TORQUE TRANSMISSION, 4:1 GEAR REDUCTION
	MOTOR:	¼ HP, 1725 RPM, TENV, CONTINUOUS DUTY
	CAPACITY:	NEAT POLYMER FLOWRATE: 0.7 TO 4.2 GPH (16 TO 100 GPD)
BOOSTER MODULE:	PUMP:	CENTRIFUGAL-TYPE, CAST IRON, MODIFIED FOR POLYMERS
	DRIVE:	CLOSE-COUPLED
	MOTOR:	.75 HP, 3450 RPM, CONTINUOUS DUTY, ODP
	DISCHARGE:	10 – 60 PSI 1.0 – 8.0 GPM
SOLUTION OUTPUT:	PRIMARY FLOW:	3.0 – 8.0 GPM (480 GPH)
	SECONDARY FLOW:	NONE
	TOTAL FLOW:	3.0 – 8.0 GPM (480 GPH)
CONCENTRATION:	SOLUTION:	PRIMARY 0.2 – 2.0% VOLUME ON VOLUME TOTAL 0.2 – 2.0% VOLUME ON VOLUME
UTILITIES:	ELECTRICAL:	120/1/60 20 AMPS
	WATER:	40 – 100 PSI 25 GPM CLEAN SOURCE
CONTROLS:	CONTROLLER:	(OPTIONAL) NEMA 4X W/ TOUCHPAD, POLYMER RATIO, REMOTE START/STOP, POLYMER PUMP READOUT, WATER RATIO, PRIMARY AND SECONDARY FLOW READOUTS, REMOTE SETPOINT AND DOSING CONTROL, AUTO CALIBRATION AND ALARMS
	LOW WATER:	(OPTIONAL) FLOW SENSOR WITH AUTO RESTART OR MANUAL RESET
	LOW POLYMER:	(OPTIONAL) OPTICAL SENSORS WITH ADJUSTABLE RANGE 0.15 – 2.0% CONCENTRATION

ENGINEERING SPECIFICATIONS:

AnCAT Model 058GS-100 shall be provided to rapidly dilute, activate and feed emulsion, dispersion and solution polymers at 480 GPH of polymer solution at concentrations to 2%. The system shall contain a four step controlled energy hydraulic circuit which instantaneously dilutes and blends the polymer to it's most efficient state for use in the process. The unit shall be designed with full pressure-controlled, inline inversion capability and shall not be limited by a minimum retention time restriction. The polymer system shall be capable of providing a 15 – 20 PSI pressure boost and shall not rely on available inlet water pressure to discharge the polymer solution product. The system shall be modular in design and shall consist of a polymer injection module, booster module, premix manifold assembly, inlet water solenoid valve, primary and secondary inlet water flowmeter, primary and secondary inlet water flow controllers, proportioning pressure regulator to balance primary and secondary flow circuits, mixing pressure regulator adjustable from 10 to 70 PSI, mixing circuit pressure gauge and inlet water throttling valve.

PLAN & ELEVATION

05GS_DIM

AnCAT 05GS-SERIES

(TYPICAL TO ALL 054GS AND 058GS SYSTEMS)

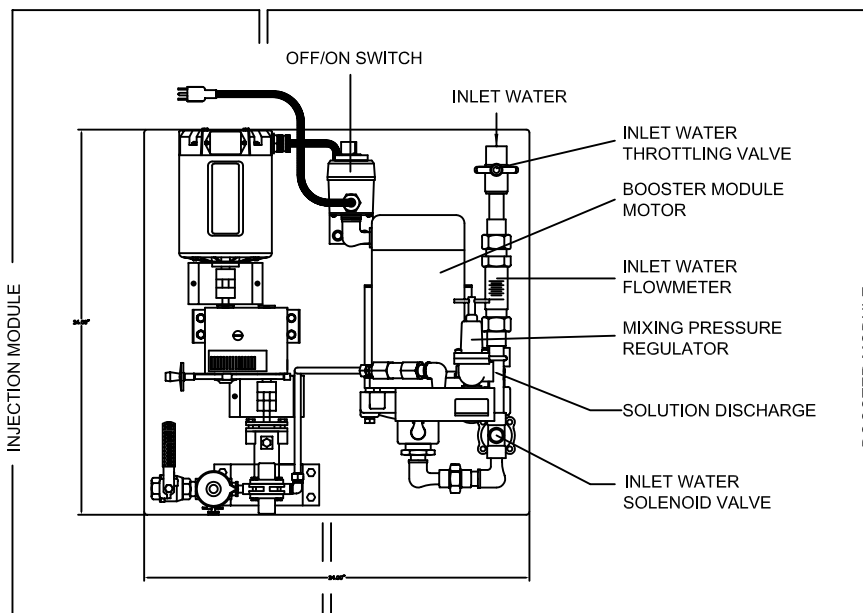
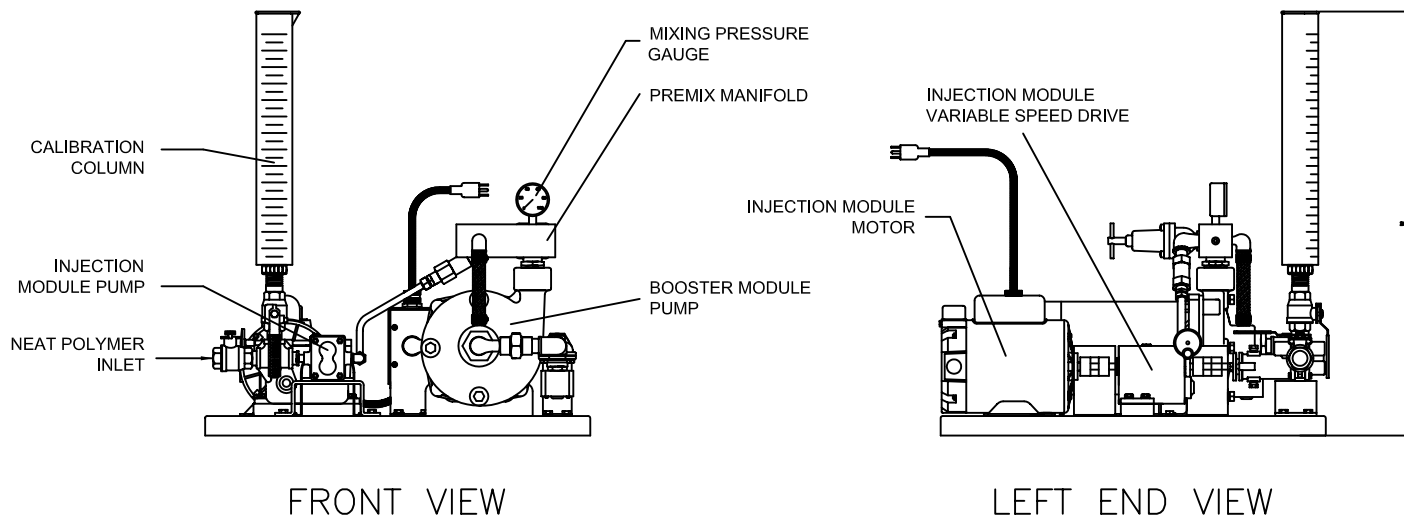

PLAN VIEW

NORCHEM INC.

ELECTRICAL SCHEMATIC

05GS_ELE

AnCAT 05GS-SERIES

(TYPICAL TO ALL 054GS AND 058GS SYSTEMS)

INCOMING POWER
115 VAC/1 PH/60 HZ

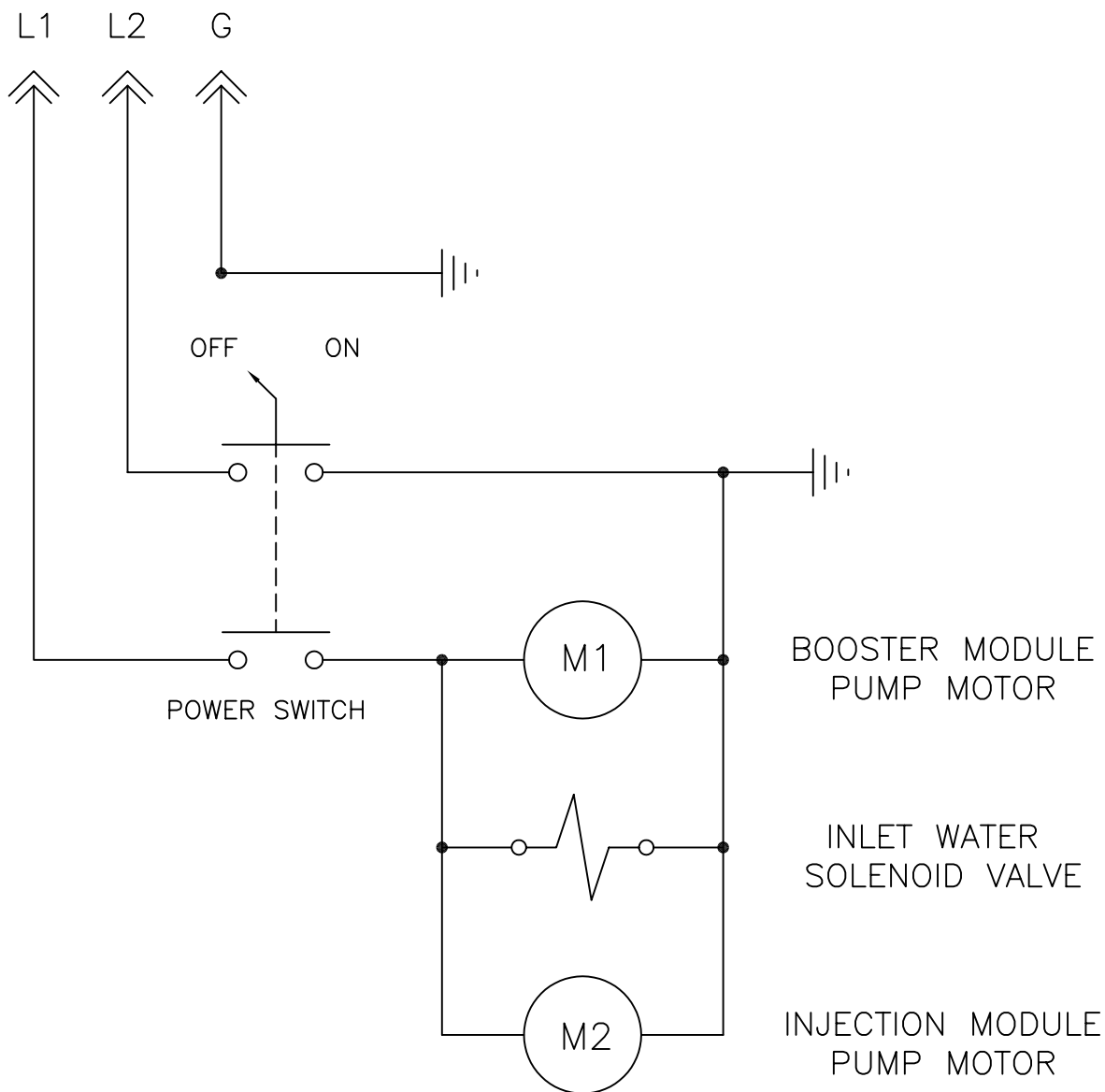

NORCHEM INC.

(TYPICAL TO ALL 054GS AND 058GS SYSTEMS)

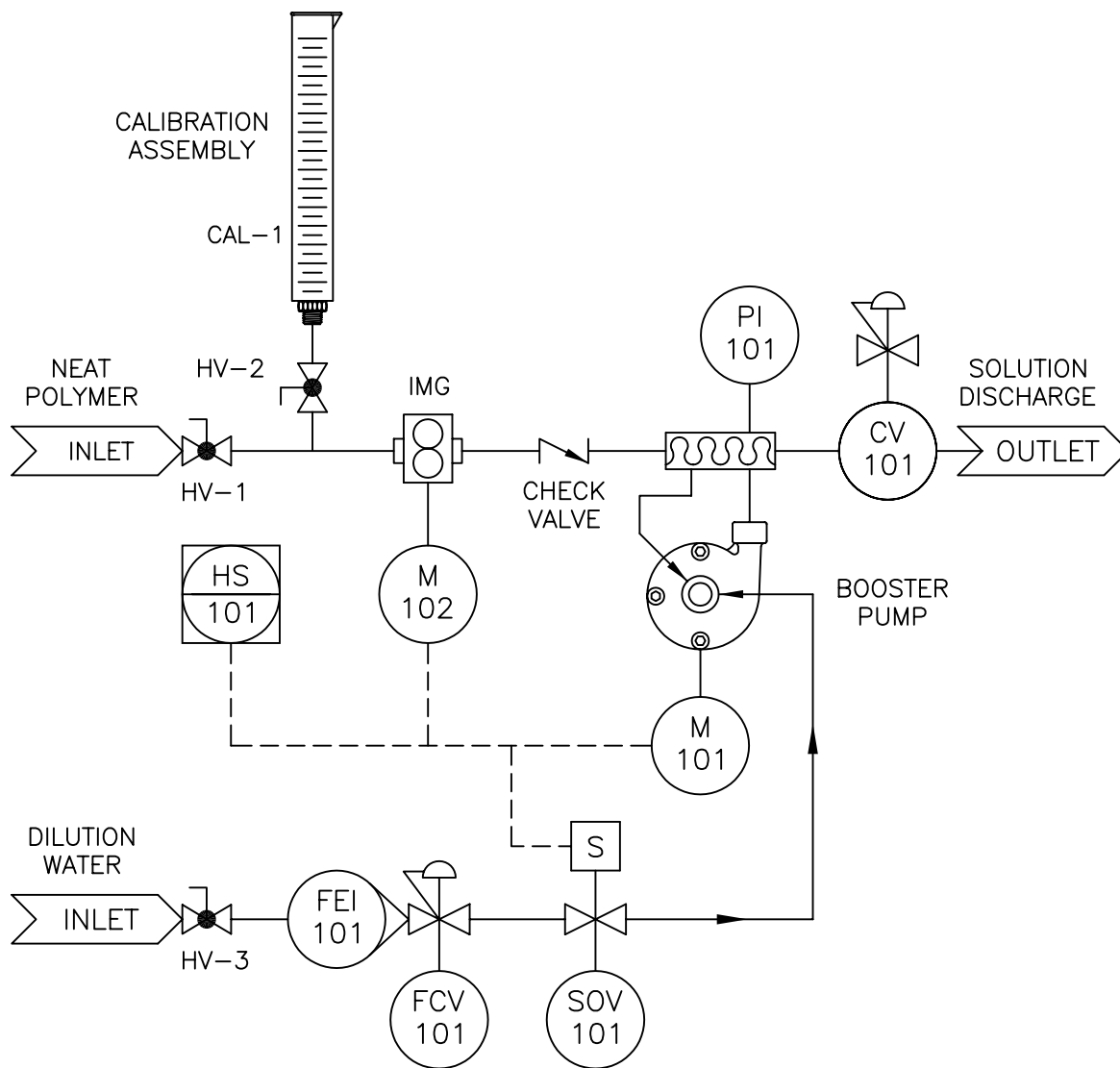

LEGEND

- | | |
|---------|---|
| HV-1 | POLYMER SUPPLY SHUTOFF HAND VALVE |
| HV-2 | CALIBRATION ASSEMBLY ISOLATION HAND VALVE |
| HV-3 | INLET WATER THROTTLING VALVE |
| CAL-1 | CALIBRATION CYLINDER |
| IMG | INJECTION MODULE GEAR PUMP |
| PI-101 | MIXING PRESSURE GAUGE |
| M-101 | BOOSTER PUMP MOTOR |
| M-102 | POLYMER INJECTION PUMP MOTOR |
| SOV-1 | DILUTION WATER INLET SOLENOID VALVE |
| CV-101 | MIXING PRESSURE CONTROL VALVE |
| FEI-101 | DILUTION WATER INDICATING FLOW METER |
| FCV-101 | DILUTION WATER FLOW CONTROL REGULATOR |
| HS-101 | OFF/ON SWITCH |